

RWK-LC

Smart Switch Controller

Convenient and intelligent control

Scene mode setting

Energy conservation and consumption reduction



Comply with IEC / CEI /GB/JB/DL standards

Provided customized manufacture

Whole solutions for design, assembly, test...

Accountable solution for safety and reliability

Wide range offering, easy business and convenient installation

Foreword

Please read this chapter carefully before using this product!

This chapter introduces the safety precautions before using this product. Please make sure the content of this chapter is fully read and understood before installation and usage. Our company will not undertake any responsibilities for any damage or injury caused by improper operations because of ignoring relevant warning in this operation instruction.

Before operating this device, relevant professional personnel shall read this instruction carefully and well understand the content.

Operation instructions and warnings:

The following standard definitions will be adopted in this operation instruction.

Danger! Ignoring of safety precautions may cause personal death, serious personal injury or serious equipment damage.

Warning! Ignoring of safety precautions may cause personal death, serious personal injury or serious equipment damage.

Caution! Ignoring of safety precautions may cause a slight personal injury or equipment damage, especially the damage of device or the equipment protected by the device.

- **Danger!**

When the primary system is live working, secondary open circuit for the current transformer connected to the device is absolutely forbidden, and the open of this circuit may cause extremely dangerous high voltage.

- **Warning!**

Some parts of the device may have high voltage when the electrical device is running. Improper operation may cause serious personal injury or equipment damage.

Only qualified professional personnel are allowed to operate the device or work nearby the device. The operators professional shall well understand the precautions, working flows and safety regulations mentioned in this instruction.

- **Caution!**

Grounding terminals of the device shall be firmly grounded.

The device is only permitted to run in atmospheric environment that specified in the technical specifications, and abnormal vibrations shall be avoided in its running environment.

When connect the AC voltage current circuit or power circuit, please make sure they conform to the rated parameters of the device.

When the output terminals of the device are connected to external circuit, please check carefully the voltage of external power to prevent overheating of the circuit.

Carefully check the cable connected to the device, preventing applying too much external force on it.

Contents

CHAPTER 1: OVERVIEW	5
1.1 Description	5
1.2 Protection	5
1.3 Supervision	5
1.4 Control.....	5
1.5 Features	5
1.6 Monitoring Functions	6
1.7 Hardware	6
1.8 Data Storage and Communication	6
CHAPTER 2: TECHNICAL PERFORMANCE INDEX.....	7
2.1 Inputs and Outputs	7
2.2 Unit Design	8
2.3 Serial Interface	8
2.4 Data Storage.....	9
2.5 Mechanical Tests	9
2.6 Electrical Tests.....	10
2.7 Climatic Tests	11
CHAPTER 3: PROTECTION FUNCTIONALITY	12
3.1 Function Description	12
3.2 Constant Value Parameters	15
CHAPTER 4: USER INTERFACE	17
4.1 LEDs	17
4.2 Keypad.....	18
4.3 LCD.....	20

4.4 The Main Menu	20
4.5 Submenu	21
4.6 Entering the password interface	22
4.7 Relay setting	23
4.9 Parameter set	29
4.10 Calibration	30
4.11 Clear report	31
4.12 Factory setting	31
4.13 View relay and setting	31
4.14 View SOE	32
4.14 View input signal	32
CHAPTER 5: PERIPHERAL ACCESSORIES	33
5.1 RF remote controller	33
5.2 Features and the use of external sockets and switches	33
5.3 The main secondary component parts	34
5.4 Battery	34
5.5 Wireless Router	34
CHAPTER 6: INSTALLATION AND MAINTENANCE	35
6.1 Installation	35
6.2 Maintenance	36
6.3 Parts Attached with the Device	36
CHAPTER 7: DECOMMISSION AND DISPOSAL	37
7.1 Decommission	37
7.2 Disposal	37

Chapter 1: Overview

1.1 Description

RWK-LC Smart Switch Controller is medium voltage overhead line grid monitoring unit, it can be equipped with RCW(RVB) type vacuum circuit breaker for achieve of automatic monitoring, fault analysis and event records.

Its given to us a safety power grid for cutting line fault and automatic recovery operation and power automation.

RWK-LC series is suitable for up to 35kV outdoor switchgear using, include: vacuum circuit breakers, oil circuit breakers and gas circuit breakers.

RWK-LC intelligent controller is gathering with line protection, control, measurement and monitoring of voltage and current signals integrated automation and control devices outdoors.

RWK is an automatic management unit for single way/multi ways/ring network/two power sourcing, provided with all voltage and current signals and all functions.

RWK-LC column switch intelligent controller supports:

Wireless (GSM/GPRS/CDMA), Ethernet mode, WIFI, optical fiber, power line carrier, RS232/485, RJ45 and other forms of communication, and can access other station premises equipment (such as TTU, FTU, DTU, etc.).

1.2 Protection

49	Thermal Overload (Over load)
50	Instantaneous Overcurrent (Ph.OC)
50G/N/SEF	Instantaneous Sensitive Earth Fault (SEF)
27/59	Under/Over Voltage (Ph.OV/Ph.UV)
51c	Cold load pickup (Cold load)

1.3 Supervision

60CTS	CT Supervision
60VTS	VT Supervision

1.4 Control

79	Auto Reclose
86	Lockout
	CB Control

1.5 Features

Password Protection – 2 levels.

50Hz systems and two phase/three phase wiring method are available, so that the use scope of device is extended.

Protection configuration is complete, and all protection functions can be switched on and off flexibly.

4-way intellectual switching value input.

Large capacity flash memory can record at least 100 times of historical events, and no data will loss even the power is off.

Circuits operating loop can be used both the direct or alternating current, self-adaptation open/close brake function, which can co-work with various of breakers, and the operation is simple and reliable.

The device has complete self-inspection function to in-service monitor the working conditions of various parts of the device, ensuring the reliability of the device.

1.6 Monitoring Functions

Primary Currents Phases and Earth Direction

Secondary PT Voltage

Frequency

Binary Input/Output status

Trip circuit healthy/failure

Time and date

Fault records

Event records

1.7 Hardware

4CT 1 VT 4 Binary Inputs 2 Binary Outputs

4CT 2 VT 4 Binary Inputs 2 Binary Outputs

1.8 Data Storage and Communication

RS485, RS232, RJ45 port

Protocols –IEC60870-5-101, IEC60870-5-104, DNP3.0 or Modbus RTU

Event Records

Fault Records

Measurands

Commands

Time Synchronism

Viewing and Changing Settings

Chapter 2: Technical Performance Index

2.1 Inputs and Outputs

Phase Current Inputs

Quantity	3
Rated Current In	5A
Measuring Range	20 x In
Instrumentation $\geq 0.1xIn$	$\pm 1\%$ In
Frequency	50Hz
Thermal Withstand:	
Continuous	2 x In
10 Second	10 x In
1 Second	40 x In
Burden @ In	$\leq 0.2VA$ (5A Phase element)

Sensitive Earth Current Inputs

Quantity	1
Rated Current In	5A
Measuring Range	2 x In
Instrumentation $\geq 0.1xIn$	$\pm 1\%$ In
Frequency	50/60Hz
Thermal Withstand:	
Continuous	2 x In
10 Second	10 x In
1 Second	40 x In
Burden @ In	$\leq 0.02VA$ (1A Earth element)

Voltage Inputs

Quantity	1 PT voltage
Nominal	40...120 Vrms
Operating Range	0...200 Vrms

Instrumentation $\geq 0.8 \times V_n$	$\pm 1\% V_n$
Burden @ 110V	0.06 VA
Overvoltage Withstand	240 Vrms

Auxiliary Supply

DC Voltage	220V Range 165 to 365V
AC Voltage	220 V AC 50Hz Range 165 to 265Vrms AC 50/60Hz $\pm 5\%$
Power consumption	$\leq 10W$

Binary Inputs

Number	4
Operating Voltage	24V DC
Maximum dc current for operation	2mA

Binary Outputs

Number	2
Operating Voltage	220V DC
Operating Mode	User selectable - Self or Hand/Electrical Reset or pulsed
Operating Time from Energizing Binary Input	<20ms

2.2 Unit Design

Indication	16 Character 4 line Display 10 LED's
User Interface	11 Navigation Keys
Weight	18kg

2.3 Serial Interface

Communication Port	RS485, RS232, RJ45
Protocols	IEC60870-5-101 IEC60870-5-104

	DNP3.0 MODBUS RTU
--	----------------------

2.4 Data Storage

Events	100 times
--------	-----------

2.5 Mechanical Tests

Vibration (Sinusoidal) --- IEC 60255-21-1 Class I

Type	Level	Variation
Vibration response	0.5gn	≤5%
Vibration withstand	1.0gn	≤5%

Shock and Bump --- IEC 60255-21-2 Class I

Type	Level	Variation
Shock response	0.5gn, 11ms	≤5%
Shock withstand	15gn, 11ms	≤5%
Bump test	10gn,16ms	≤5%

Shock and Bump --- IEC 60255-21- 3 Class I

Type	Level	Variation
Seismic response	X-plane-3.5mm Displacement below crossover freq (8-9Hz) 1gn and above Y-plane-1.5mm Displacement below crossover freq (8-9Hz) 0.5gn above	≤5%

Mechanical Classification

Durability	>106 operations
------------	-----------------

2.6 Electrical Tests

Insulation --- IEC 60255-5

Type	Level
Between any terminal and earth	2.0 kV AC RMS for 1 min
Between independent circuits	2.0 kV AC RMS for 1 min
Across normally open contacts	kV AC RMS for 1 min

High Frequency Disturbance --- IEC 60255-22-1 Class III

Type	Level	Variation
Common (longitudinal) mode	2.5 kV	≤5%
Series (transverse) mode	1.0 kV	≤5%

High Frequency Disturbance --- IEC 60255-22-2 Class IV

Type	Level	Variation
Contact discharge	8.0 kV	≤5%

Fast Transients --- IEC 60255-22-4 Class A (2002)

Type	Level	Variation
5/50 ns 2.5 kHz repetitive	4 kV	≤5%

Surge Immunity --- IEC 60255-22-5

Type	Level	Variation
Analog Inputs: Line to Earth	4.0 kV	≤10%
Case, Aux Power & I/O: Line to Earth	2.0 kV	≤10%
RS485 Comms port: Line to Earth	1.0 kV	No Data Loss
Analog Inputs: Line to Line	1.0 kV	≤10%
Case, Aux Power & I/O: Line to Line	1.0 kV*	≤10%

* Note 45ms DTL pick-up delay applied to binary inputs

Conducted Radio Frequency Interference --- IEC 60255-22-6

Type	Level	Variation
0.15 to 80 MHz	10 V	≤5%

Radiated Radio Frequency --- IEC 60255-25

Type	Limits at 10 m, Quasi-peak
30 to 230 MHz	40 dB(μV)
230 to 10000 MHz	47 dB(μV)

Conducted Radio Frequency

Type	Limits	
	Quasi-peak	Average
0.15 to 0.5 MHz	79 dB(μV)	66 dB(μV)
0.5 to 30 MHz	73 dB(μV)	60 dB(μV)

Radiated Immunity --- IEC 60255-22-3 Class III

Type	Level
80 MHz to 1000 MHz Sweep	10 V/m
1.4GHz to 2.7GHz Sweep	10 V/m
80,160,380,450,900,1850,2150 MHz Spot	10 V/m

2.7 Climatic Tests

Temperature --- IEC 60068-2-1/2

Operating Range	-10°C to +55°
Storage range	-25°C to +70°

Humidity --- IEC 60068-2-78

Operational test	56 days at 40°C and 93% relative humidity
------------------	---

Chapter 3: Protection Functionality

3.1 Function Description

Under Voltage (Ph.UV)

The device take the PT voltage as the criterion for under voltage protection.

Action Logic diagram :

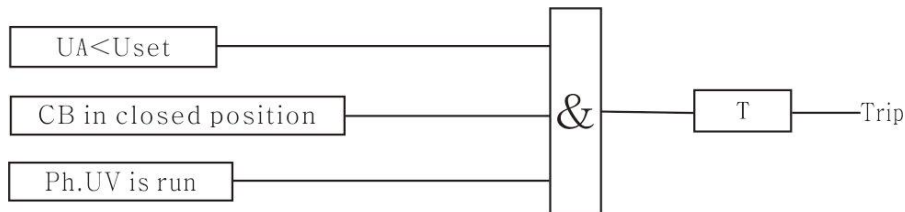

Note: Run is "√", Stop is "×".

UA—Secondary PT voltage Uset—Pickup voltage T—Delay time

Power on

The device will control the CB to close when the PT voltage greater than pickup voltage.

Action Logic diagram :

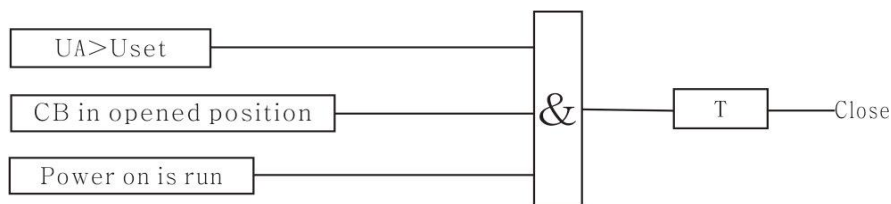

Note: Run is "√", Stop is "×".

UA—Secondary PT voltage Uset—Pickup voltage T—Delay time

Over Voltage (Ph.OV)

The device take the PT voltage as the criterion for over voltage protection.

Action Logic diagram :

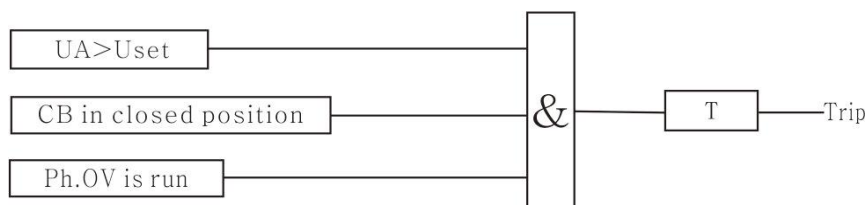

Note: Run is "√", Stop is "×".

UA—Secondary PT voltage Uset—Pickup voltage T—Delay time

51c Cold Load Pickup (Cold Load)

If a circuit breaker is closed onto a "cold" load, i.e. one that has not been powered for a prolonged period, this can impose a higher than normal load-current demand on the system which could exceed normal settings. These conditions can exist for an extended period and must not be interpreted as a fault. To allow optimum setting levels to be applied for normal operation, the cold load pickup feature will apply alternative current settings for a limited period. The feature resets when either the circuit breaker has been closed for a settable period, or if the current has reduced beneath a set level for a user set period.

Action Logic diagram:

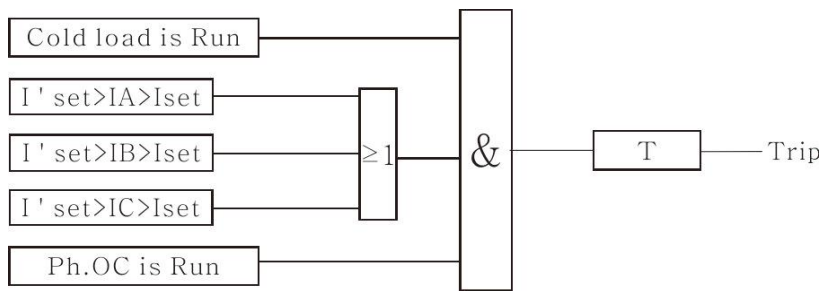

Note: Run is "√", Stop is "×".

I'set—Cold load pickup current Iset—Ph.OC pickup current T—Delay time

50/51/51V/67 Phase Fault (Ph.OC)

Three sections phase overcurrent protection for lines include Ph.OC1 (instantaneous overcurrent protection), Ph.OC2 (definite time overcurrent protection) and Ph.OC3 (overcurrent protection). All of which are definite time actuate features.

Action Logic diagram:

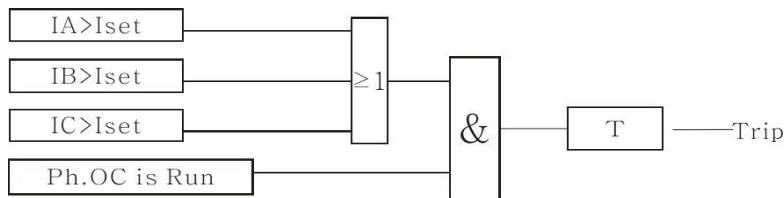

Note: Run is "√", Stop is "×".

IA IB IC—Measured current Iset—Pickup current T—Delay time

50G/51G/50N/51N Sensitive Earth Fault (SEF)

The sensitive earth fault protection is definite time limit.

Action Logic diagram:

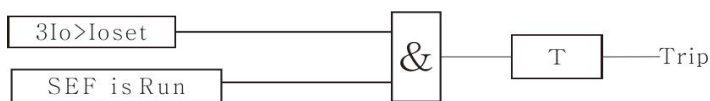

Note: Run is "√", Stop is "×".

3I0—SEF current I0set—Pickup current T—Delay time

79 Auto - Reclose (Reclose)

A high proportion of faults on an overhead line network are transient and can be cleared quickly by high speed tripping followed by an automated circuit breaker reclose sequence.

The function provides phase fault and earth fault/sensitive earth fault sequences of up to 5 trip i.e.4 reclose attempts before lockout, and the charging period of the reclose is 10 seconds.

Action Logic diagram:

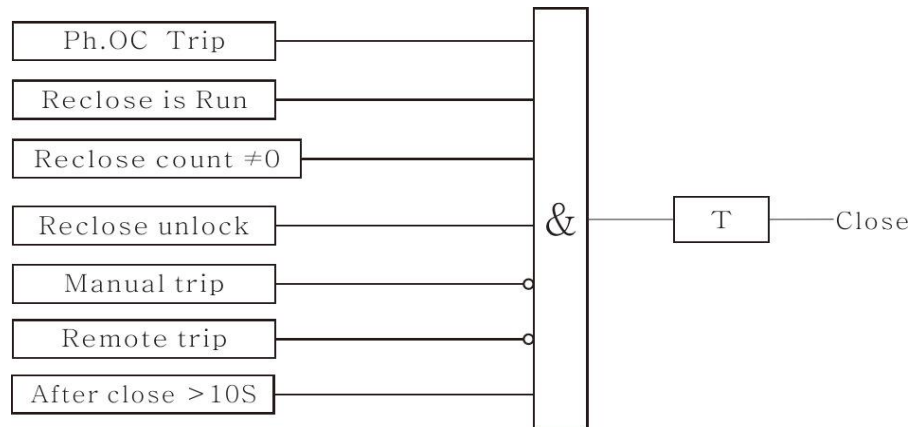

Note: Run is "√", Stop is "×".

Reclosing acceleration (Recl.ACC)

When switching on reclosing acceleration, if accidents happened in 3S after the reclose is operated, the phase over current protection will accelerate the operation.

Action Logic diagram:

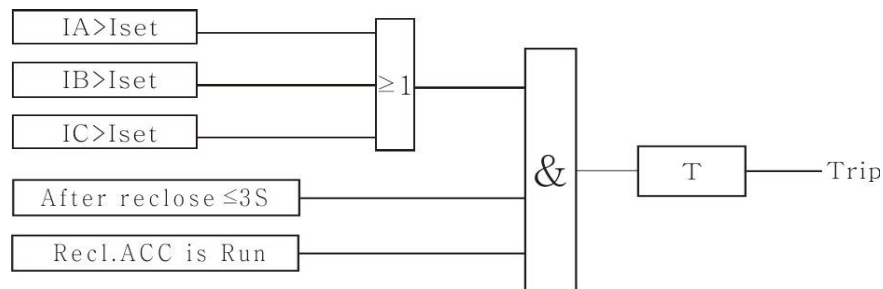

Note: Run is "√", Stop is "×".

IA IB IC—Measured current Iset—Pickup current T—Delay time

Manual closing acceleration (Manu.ACC)

When switching on manual closing acceleration, if accidents happened in the exit time after operated the close, the phase over current protection will accelerate the operation. The exit time of acceleration can be adjusted.

Action Logic diagram:

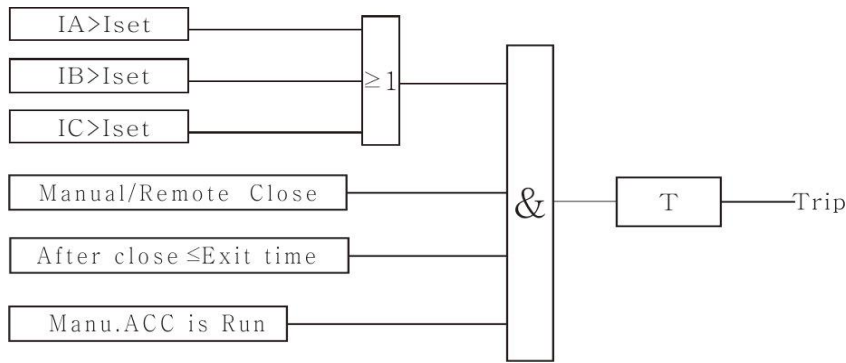

Note: Run is "√", Stop is "×".

IA IB IC—Measured current Iset—Pickup current T—Delay time

Prepaid (Optional features)

It is used to connect the dosing tank, the device will control the CB to trip when the dosing tank is in deficit.

Action Logic diagram:

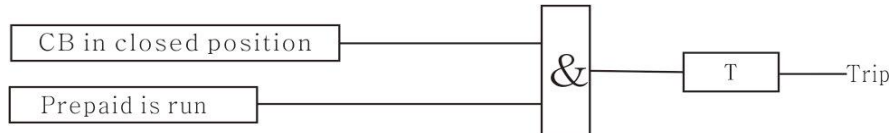

Note: Run is "√", Stop is "×".

3.2 Constant Value Parameters

All values are given primary side.

Under Voltage (Ph.UV)

Description		Setting range	Step length
PH.UV	Pickup voltage	0 ~ 999.9V	0.1V
	Delay time	0 ~ 99.99S	0.01S

Power on

Description		Setting range	Step length
Power on	Pickup voltage	0~999.9V	0.1V
	Delay time	0 ~ 99.99S	0.01S

Over Voltage (Ph.OV)

Description		Setting range	Step length
PH.OV	Pickup voltage	0~999.9V	0.1V
	Delay time	0 ~ 99.99S	0.01S

51C Cold Load Pickup (Cold load)

Description		Setting range	Step length
Cold load	Pickup current	1 ~ 6000A	0.1A
	Delay time	0 ~ 99.99S	0.01S

50/51/51V/67 Phase Fault (Ph.OC)

Description		Setting range	Step length
PH.OC1	Pickup current	0.1 ~ 6000A	0.1A
	Delay time	0 ~ 9.99S	0.01S
PH.OC2	Pickup current	0.1 ~ 6000A	0.1A
	Delay time	0 ~ 9.99S	0.01S
PH.OC3	Pickup current	0.1 ~ 6000A	0.1A
	Delay time	0 ~ 99.99S	0.01S

50G/N Sensitive Earth Fault (SEF)

Description		Setting range	Step length
SEF	Operating mode	1.Alarm 2.Trip	
	Pickup current	0.1 ~ 999.9A	0.1A
	Delay time	0 ~ 600S/M	0.1S/M

79 Auto - Reclose (Reclose)

Description		Setting range	Step length
Reclose	Reclose count	1:One 2:Two 3:Three 4:Four	
	Delay time	0 ~ 99.99S	0.01S
	Reset time	1.2 ~ 180S	0.1S

Reclosing acceleration (Recl.ACC)

Description		Setting range	Step length
Recl.ACC	Pickup current	0.1 ~ 6000A	0.1A
	Delay time	0 ~ 9.99S	0.01S

Manual closing acceleration (Manu.ACC)

Description		Setting range	Step length
Manu.ACC	Exit time	0.1 ~ 9.99S	0.01S
	Pickup current	0.1 ~ 6000A	0.1A
	Delay time	0 ~ 9.99S	0.01S

Prepaid (Optional features)

Description		Setting range	Step length
Prepaid	Delay time	0 ~ 99.99S	0.01S

Chapter 4: User Interface

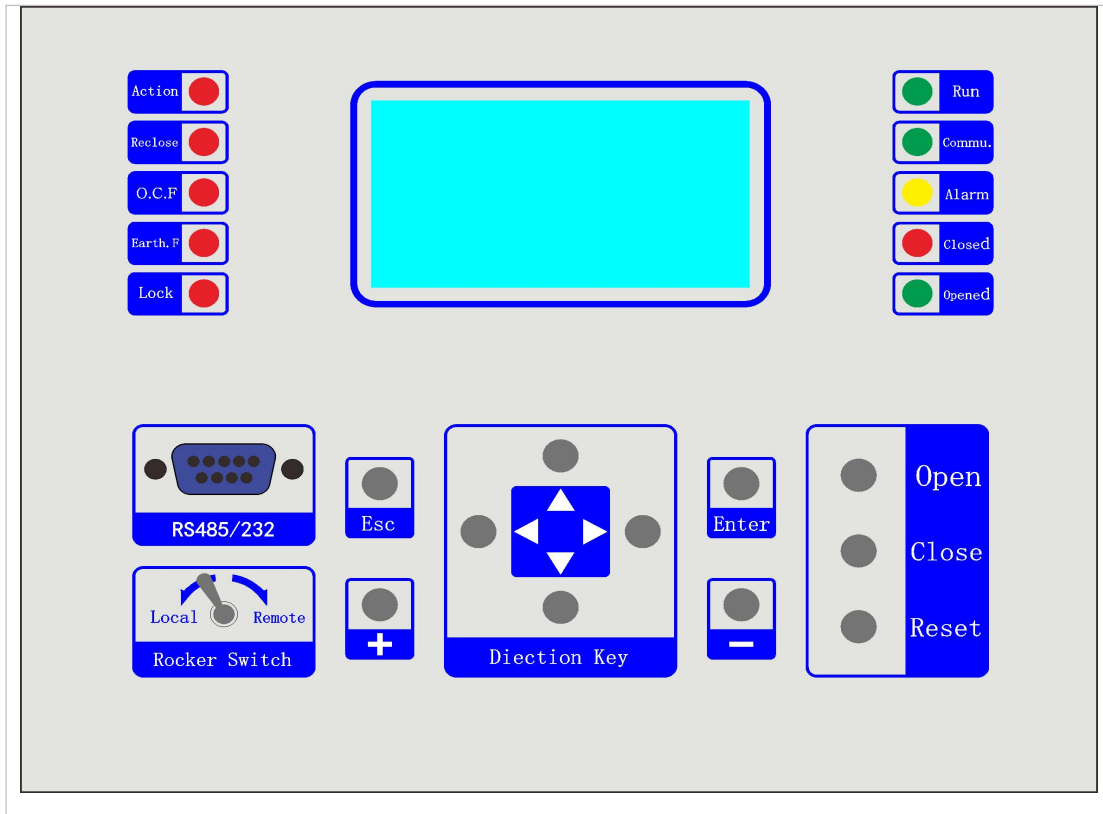

The operator interface is designed to provide a user friendly method of controlling, viewing menus, entering settings and retrieving data from the relay. 11 buttons are provided for navigation around the menu structure.

4.1 LEDs

<p>Operation Status</p>	<p>Operation Status</p>







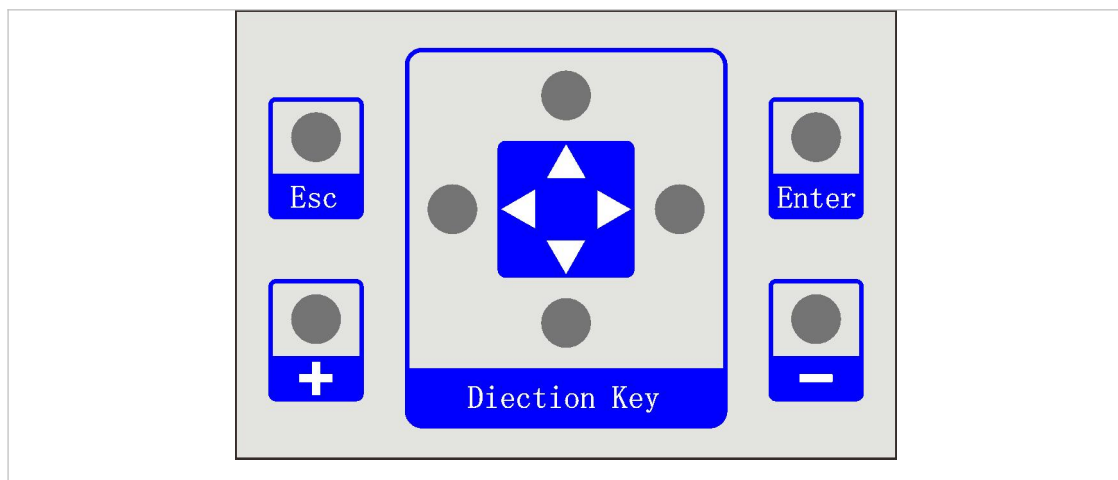

LED Categories		LED Status		
Name	Color	ON	OFF	Flashing
Run	Green	crash	crash	Working properly
Commu	Green	No communication	No communication	Normal communication
Alarm	Yellow	Device failure or protection alarm	Running normally	—
Closed	Red	Switch is on	Switch is not on	—
Opened	Green	Switch is off	Switch is not off	—
Action	Red	Protective action	No protective action	—
Reclos	Red	Reclose export	Normal	—
OC.F	Red	Over current alarm	Normal	—
Earth.F	Red	Ground fault action	Normal	—
Lockout	Red	Reclosing lockout alarm	Normal	—

4.2 Keypad

The main keys



User actions are mainly concentrated on the operation panel.



Key	Function
	Increase the number
	Reduce the number
	Move up or page up
	Move down or page down
	Move left
	Move right
	Return to the superior or Cancel the operation
	Enter the menu of confirm the operation

When you press the button, the buzzer of device will sing make a sound, so that the operation is valid; if not, please do it again.

Operation buttons

Key	Function
	Touch reset button, you can reset protect information
	Touch closing button, close switch
	Touch tripping button, trip switch

When you press the button, the buzzer of device will make a sound, so that the operation is valid; if not, please do it again.

Note: When you press the closing-button or tripping-button, you must make sure the device is unlock; if the lockout-light is on, please press the reset-button to reset the device, so that you can close or trip the switch.

4.3 LCD

A 4 line by 16 character liquid crystal display with power save operation indicates the relay identifier, settings, instrumentation, fault data and control commands.

4.4 The Main Menu



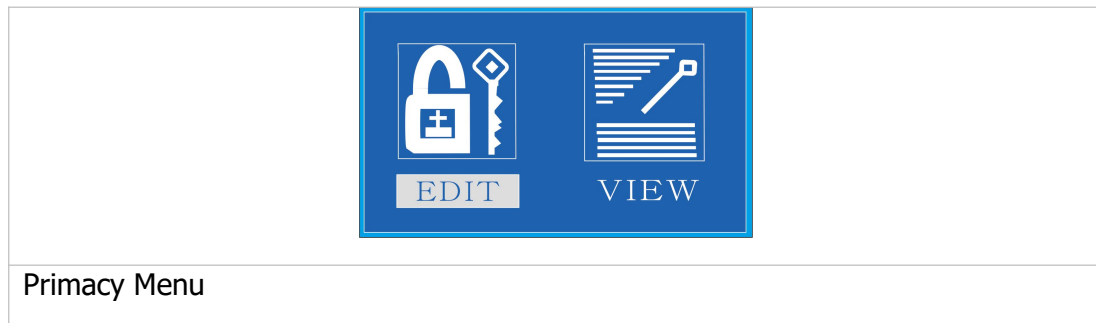











Press "Enter" when on the main screen, as shown below, including "EDIT" and "VIEW" menu item. Select the corresponding menu item with the [←] key, [→] and press "Enter" button to enter the corresponding sub-menu, press the "ESC" key to return to the previous screen.



4.5 Submenu



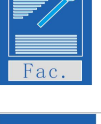



Edit submenu

Choose the edit options, the screen will enter the submenu of the Edit menu, as shown below, the submenu includes "Relay", "Para", "Chnl", "Clr", "Time", "Comm", "Fac", "Test".

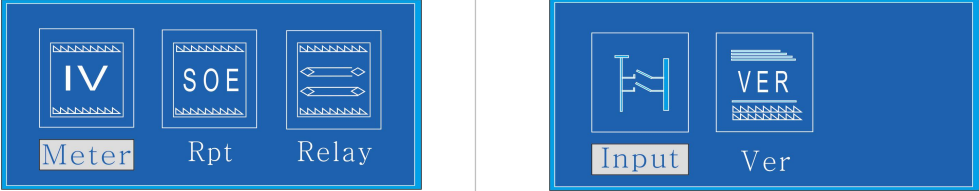
 Relay	   Clr. Time Comm	  Fac. Test
Submenu of edit		
 Relay	Enter "Relay" submenu, you can modify the protection feature.	
 para	Enter "Para" submenu, you can modify or view other parameters. Like communication address, baud rate, password, trip and close pulse time.	
 Adj.	Enter "Adj." submenu, current and voltage values can be corrected, press the function key "Enter" to be modified.	
 Clr.	Enter "Clr." submenu, you can clear out the trip report, the alarm report, the SOE report, the count report and all report.	
 Time	Enter the "Time" submenu will modify or check the time.	
 Comm	Enter "Comm" Sub-menu, choose the way to communication, it include "GSM"and "GPRS".	
 Fac.	Enter "Fac." Sub-menu, modify and view the factory settings.	
 Test	Enter "Test" Sub-menu, it can test the life of the switch, set the number of reclosing and the interval time of each reclosing.	

View submenu

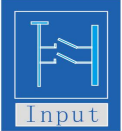
Choose the view options, the screen will enter the submenu of the View menu, as shown below, the sub-menu includes "Meter", "RPT", "Relay", "Input", "Ver".

	
<h3>View submenu</h3>	
	<p>Enter "Meter" submenu, you can view the primary side measurement data include: PT voltage, phase current, zero sequence current, frequency, phase angle.</p>
	<p>Enter "RPT" submenu, you can view trip report, alarm report, SOE report, count report.</p>
	<p>Enter "Relay" submenu, you can view each protection feature is invested and set up the parameters</p>
	<p>Enter the "Input" submenu, you can view the input signal. The input signal includes: Breaker close, Prepaid open, Prepaid close, Spring ready.</p>
	<p>Enter "Ver" submenu, you can view the product model, serial number and date of manufacture.</p>













4.6 Entering the password interface

According to the above operation, before entering each item will first enter a password input interface to prevent professional staff misuse. The device original password is "0099", as shown below, press [←] and [→] keys to switch, press the [+] and [-] keys to increase and decrease the number of line with the correct password press "Enter" button to enter.

<p>Password interface</p>

4.7 Relay setting

Select the "Relay" in the Edit submenu item, press the function key "Enter" to enter the password screen, enter the correct password to enter the "Relay" submenu, as Shown below, each item has a checkbox and set values.

Ph.OC1: ✓ 	1、 Ph.OC1: instantaneous overcurrent Protection
Ph.OC2: X 	2、 Ph.OC2: definite time overcurrent protection
Ph.OC3: X 	3、 Ph.OC3: overcurrent protection
SEF: X 	4、 SEF: sensitive earth fault protection
Cold load: ✓ 	5、 Cold Load: cold load pickup
Reclose: ✓ 	6、 Reclose: OC/SEF reclose
Recl.ACC: X 	7、 Recl.ACC: reclosing acceleration protection
Manu.ACC: X 	8、 Manu.ACC: manual closing acceleration protection
Ph.OV: X 	9、 PH.OV: over-voltage protection
Ph.UV: ✓ 	10、 PH.UV: low-voltage protection
Power on: X 	11、 Power on: power on protection
Prepaid: X 	12、 Prepaid: debt protection
Power Alm: X	13、 Power Alm: stored energy alarm

Three sections phase overcurrent

Normal overcurrent

Select Ph.OC menu  option press "Enter" key to enter, operational processes as shown below:

<pre>Ph.OC1(1/2) Pickup current: 0100.0 A Scp: 00.1 -6000.0</pre>	<p>Step 1: Setting the overcurrent protection current value, the current value can be between 0.1A ~ 6000A.</p>
<pre>Ph.OC1(2/2) Delay time : 0.00 S Scp: 0.00-9.99</pre>	<p>Step 2: Setting the overcurrent delay time, the delay time can be between 0S ~ 9.99S.</p> <p>Note: Press [↓] key to switch to next screen, press the [+] and [-] keys to switch the modified current value and delayed time.</p>
<p>The operational processes of simple overcurrent protection setting</p>	

Note: Here is a three-stage overcurrent protection period, the use of the other two are the same.

Sensitive earth fault

Select SEF menu  option press "Enter" key to enter, operational processes as shown below:

<pre>SEF(1/3) Operating mode: 2 Scp: 1 -2</pre>	<p>Step 1: Choose the SEF operating mode (1: Alarm 2: Trip).</p>
<pre>SEF(2/3) Pickup current: 004.0 A Scp: 00.1-999.9</pre>	<p>Step 1: Setting the SEF protection current value, the SEF current value can be between 0.1A ~ 999.9A.</p>
<pre>SEF(3/3) Delay time : 000.1 S</pre>	<p>Step 2: Setting the SEF delay time, the delay time can be between 0 ~ 600.0S/M.</p>
<p>The operational processes of SEF protection setting</p>	

Cold Load

Select Cold Load menu  option press "Enter" key to enter, operational processes as shown below:

<pre> Cold load(1/2) Pickup current: 1000.0 A Scp: 01.0 -6000.0 ↓ Cold load(2/2) Delay time : 01.00 S Scp: 0.00-99.99 </pre>	<p>Step 1: Setting the cold load protection current value, the current value can be between 1A ~ 6000A.</p> <p>Step 2: Setting the cold load delay time, the delay time can be between 0S ~ 99.99S.</p> <p>Note: Press [↓] key to switch to next screen, press the [+] and [-] keys to modified current value and delayed time.</p>
<p>The operational processes of cold load protection setting</p>	

Automatic reclosing (Reclose)

Select Reclose menu  option press "Enter" key to enter, operational processes as shown below:

<pre> Reclose(1/6) Reclose count: 1 Scp: 1 -4 ↓ Reclose(2/6) 1st delay time: 04.00 S Scp: 0.00-99.99 ↓ Reclose(3/6) 2nd delay time: 04.00 S Scp: 0.00-99.99 ↓ Reclose(4/6) 3rd delay time: 04.00 S Scp: 0.00-99.99 ↓ Reclose(5/6) 4th delay time: 04.00 S Scp: 0.00-99.99 ↓ Reclose(6/6) Reset time: 060 S Scp: 01.2-180.0 </pre>	<p>Step 1: Choose the reclosing times (1: One, 2: Two, 3: Three, 4: Four).</p> <p>Step 2: Setting the 1st delay time, the delay time can be between 0S ~ 99.99S.</p> <p>Step 3: Setting the 2nd delay time, the delay time can be between 0S ~ 99.99S.</p> <p>Step 4: Setting the 3rd delay time, the delay time can be between 0S ~ 99.99S.</p> <p>Step 5: Setting the 4th delay time, the delay time can be between 0S ~ 99.99S.</p> <p>Step 6: Setting the reclosing reset time, the reset time can be between 1.2S~ 180.0S.</p> <p>Note: Press [↓] key to switch to next screen, press the [+] and [-] keys to switch the mode and modified delayed time/reset time.</p>
<p>The operational processes of automatic reclosing setting</p>	

Reclosing acceleration (Recl.ACC)

Select Recl.ACC menu  option press "Enter" key to enter, operational processes as shown below:

<pre> Recl.ACC(1/2) Pickup current: 0100.0 A Scp: 00.1 -6000.0 </pre> <p style="text-align: center;">↓</p> <pre> Recl.ACC(2/2) Delay time : 0.00 S Scp: 0.00-9.99 </pre>	<p>Step 1: Setting the Recl.ACC protection current value, the current value can be between 0.1A ~ 6000A.</p> <p>Step 2: Setting the delay time, the delay time can be between 0S ~ 9.99S.</p> <p>Note: Press [↓] key to switch to next screen, press the [+] and [-] keys to switch the modified current value and delayed time.</p>
<p>The operational processes of reclosing acceleration protection setting</p>	

Manual closing acceleration (Manu.ACC)

Select Manu.ACC menu  option press "Enter" key to enter, operational processes as shown below:

<pre> Manu.ACC(1/3) Exit time : 9.99 S Scp: 0.10-9.99 </pre> <p style="text-align: center;">↓</p> <pre> Manu.ACC(2/3) Pickup current: 0100.0 A Scp: 00.1 -6000.0 </pre> <p style="text-align: center;">↓</p> <pre> Manu.ACC(3/3) Delay time : 0.00 S Scp: 0.00-9.99 </pre>	<p>Step 1: Setting the Manu.ACC exit time, the exit time can be between 0.1S ~ 9.99S.</p> <p>Step 2: Setting the Manu.ACC protection current value, the current value can be between 0.1A ~ 6000A.</p> <p>Step 3: Setting the delay time, the delay time can be between 0S ~ 9.99S.</p> <p>Note: Press [↓] key to switch to next screen, press the [+] and [-] keys to switch the modified current value and delayed time.</p>
<p>The operational processes of manual acceleration protection setting</p>	

Over voltage protection (Ph.OV)

Select PH.OV menu  option press "Enter" key to enter, operational processes as shown below:

<pre>Ph.OV (1/2) Pickup voltage: 50.0 V Scp:00.0 -999.9</pre>	<p>Step 1: Setting the Ph.OV protection voltage value, the voltage value can be between 0V ~ 999.9V.</p>
<pre>Ph.OV (2/2) Delay time : 00.00 S Scp:0.00-99.99</pre>	<p>Step 2: Setting the delay time, the delay time can be between 0S ~ 99.99S.</p>
<p>The operational processes of overvoltage protection setting</p>	

Low-voltage protection (Ph.UV)

Select PH.UV menu  option press "Enter" key to enter, operational processes as shown below:

<pre>Ph.UV(1/2) Pickup voltage: 50.0 V Scp:00.0 -999.9</pre>	<p>Step 1: Setting the Ph.UV protection voltage value, the voltage value can be between 0V ~ 999.9V.</p>
<pre>Ph.UV(2/2) Delay time : 00.00 S Scp:0.00-99.99</pre>	<p>Step 2: Setting the delay time, the delay time can be between 0S ~ 99.99S.</p>
<p>The operational processes of low voltage protection setting</p>	

Power on

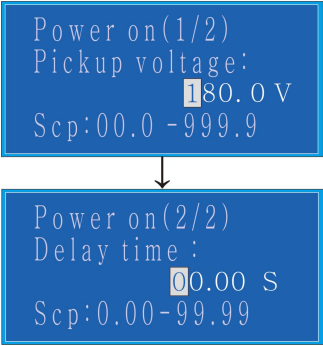

Select Power on menu option press "Enter" key to enter, operational processes as shown below:

 <pre>Power on(1/2) Pickup voltage: 180.0 V Scp:00.0-999.9</pre>	<p>Step 1: Setting the Power on protection voltage value, the voltage value can be between 0V ~ 999.9V.</p> <p>Step 2: Setting the delay time, the delay time can be between 0S ~ 99.99S.</p> <p>Note: Press [↓] key to switch to next screen, press the [+] and [-] keys to switch the modified voltage value and delayed time.</p>
<p>The operational processes of Power on protection setting</p>	

Prepaid (Optional features)



Select Prepaid menu option press "Enter" key to enter, operational processes as shown below:

 <pre>Prepaid (1/1) Delay time: 00.00 S Scp:0.00-99.99</pre>	<p>Step 1: Setting the delay time, the delay time can be between 0S ~ 99.99S.</p> <p>Note: Press the [+] and [-] keys to switch the delayed time.</p>
<p>The operational processes of Prepaid protection setting</p>	

4.8 Save parameter

After setting, press "ESC" key to exit, if modified below figure will show. If you need to save press "Enter" key and input password, otherwise press "ESC" key.



4.9 Parameter set

Press the EDIT → Para, enter the "parameter set".

Set the communication parameter

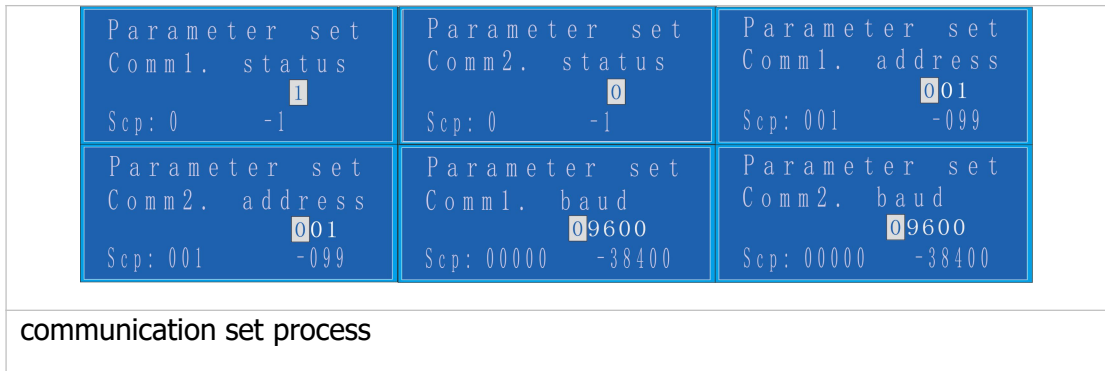

If you want to open the communication, you can set "Comm1.status" to "1", set "Comm1.address" to 001 and set "comm1.baud" to 09600 so the communication is run. "Comm1.address" is the address of the device, it used to distinguish the controller, when more than one controller need communication.

Password set

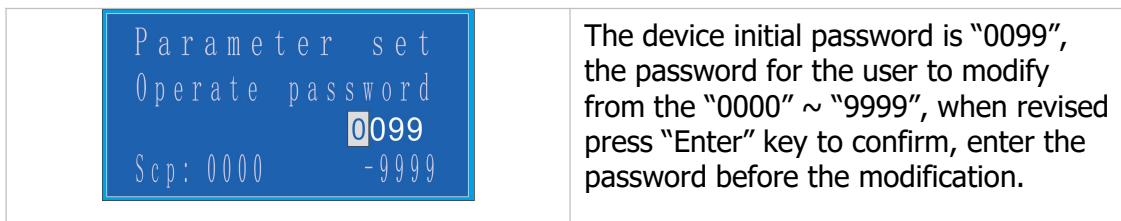

CT, CT0 rate set

<pre>Parameter set CT rate 600/5 Scp: 001/1 -999/5</pre>	CT rate is the three phase current rate. The value of CT ratio is equal to the primary side current value divided by the secondary side current value.
<pre>Parameter set CT0 rate 20/1 Scp: 001/1 -999/5</pre>	CT0 rate is the real zero sequence current rate. The value of CT0 ratio is equal to the primary side current value divided by the secondary side current value.

Note:

- 1 Different current transformer, CT ratio becomes different.
- 2 Different current transformer, CT0 ratio becomes different.

Close and trip pulse time set

<pre>Parameter set Close pulse time 60 mS Scp: 010 -999</pre>	<pre>Parameter set Trip pulse time 40 mS Scp: 010 -999</pre>
---	--

"Close pulse time" is the discharge time for close coil. "Trip pulse time" is the discharge time for trip coil.

Note: Please do not modify the trip and close pulse time.

4.10 Calibration

Select the Edit submenu in "Adj.", press "Enter" key to enter into the password screen, enter the correct password to enter the "Adj." submenu, press the [+] and [-] keys to correct the value of current and voltage.

Note: All voltage and current values in the factory have been corrected before. Please do not change the parameter values.

4.11 Clear report

Select the Edit submenu in "Clr", press "Enter" key to enter, as shown below:

1.Clear trip 2.Clear alarm 3.Clear SOE 4.Clear count	Select "1": Clear the trip report.
5.Clear all	Select "2": Clear the alarm report.
	Select "3": Clear the SOE report.
	Select "4": Clear the count report.
	Select "5": Clear the all report (include trip record, alarm record, SOE record and count record) .













4.12 Factory setting

All the values in the factory have been corrected before. Please do not change the values.

4.13 View relay and setting





Enter the main menu select the "VIEW" option press "Enter" key to enter, and then select the "Relay" option to press "Enter" key to enter the "Relay" submenu, you can

view all the protection is enabled or disabled, select the  option press "Enter" key to enter the value you can view each protection, press the arrow keys to switch screens.

Ph.OC1: √  Ph.OC2: X  Ph.OC3: X  SEF: X 
Cold load: √  Reclose: √  Recl.ACC: X  Manu.ACC: X 
Ph.OV: X  Ph.UV: √  Power on: X  Prepaid: X 
Power Alm: X

4.14 View SOE

Enter the main menu select the "VIEW" option press "Enter" key to enter, and then select "RPT" option press "Enter" key to enter the "RPT" submenu, you can view the SOE record events, recording events include: trip signal, alarm signal, telemetry signal (circuit breaker status, whether the manual or remote operation, fault trip, time and date, etc.) and count signal (the count of trip).

 Trip  Alm  Sig	2013-11-07<092> 15:27:36.678 A P OC1 Trip I=05.06	2013-05-07<022> 10:27:36.678 A P Alm:control loop break	2013-10-05<098> 15:47:36.678 A P Start device 1→1
 Cnt.	OC= 4 SEF= 1 Manual= 10 Remote= 0	Other= 4 All= 19	

4.14 View input signal

Enter the main menu select the "VIEW" option press "Enter" key to enter, and then select the "Input" option press "Enter" key to enter the "Input" submenu, you can view the state of input signal.

Input show Breaker close: 1 Prepaid open: 0 High temp: 0	Input show High gas: 0 Light gas: 0 Spring ready: 0
---	--

Chapter 5: Peripheral Accessories

5.1 RF remote controller

	<p>Function of each key</p> <p>A:Close</p> <p>B:Trip</p> <p>C:Unlock</p> <p>D:Reset</p>
---	---

Note:

1. In order to prevent misuse, press the unlock button for 3 seconds, before execution of the closing operation.
2. The effective distance of RF remote controller is 30 meters.



5.2 Features and the use of external sockets and switches

		
AC power switch	Backup switch	Activation button

Note: Before using the controller, ensure that the battery charge enough for 12 hours.

1. The AC power switch is for protecting the Auxiliary PT (Or utility incomer), and the BACKUP switch is for charging batteries.
2. After charging the batteries, turn off the power switch to protect the batteries for storage.
3. Activation button is not allowed for pressing last long time, or permanent damage of battery under-voltage may result.

5.3 The main secondary component parts

	
Cable plug, connect the controller and circuit breakers.	Cable plug, connect the controller to offer the power.

Note: For security norms, Surge protector has to be grounded (green line) to the earth.

5.4 Battery

- RWK-2RC stand-by battery adopts two 7AH lead-acid free of maintenance batteries, the average battery life exceeds 3 years.
- Please replace the storage battery in time when the storage battery exceeds its usage life. Replace method as following: firstly push the stand-by power supply switch to trip position, and pull out the connection cable simultaneously, rotate the support bolt away, replace the used battery with new battery. Then recover the device to the original status according to the contrary sequence. Please deal with the used battery properly in order not to pollute the environment.

5.5 Wireless Router

Wireless Router is a type of compact industrial wireless router, designed to fully meet the needs of industrial standards and industrial users. It adopts high-powered industrial 32-bits CPU, multi-layer software detection and hardware protection mechanism to ensure reliability and stability of the device. It supports worldwide carrier 4G/3G cellular network FDD-LTE, TD-LTE, and WCDMA, EVDO, TD-SCDMA, EDGE, CDMA 1X and GPRS, CAT-M, NB-IoT. With rich VPN protocols (IPSEC, PPTP, L2TP etc.) to ensure the security of data transmission, and rich interfaces, such as RS232 (or RS485/RS422), Ethernet Port, I/O (Option) and WIFI (Option), etc.



Chapter 6: Installation and Maintenance

Danger: The dangerous voltage with the device maybe result in the permanent damage of equipment or personnel casualty during installing RWK-2RC. These voltages mainly distributes at terminal bar of device and circuits of AC current input, AC voltage input, digital input, IGBT output and operation power supply., etc. This device's installation, debugging and maintenance can only be operated by technical staff who has been authorized and trained strictly.

6.1 Installation

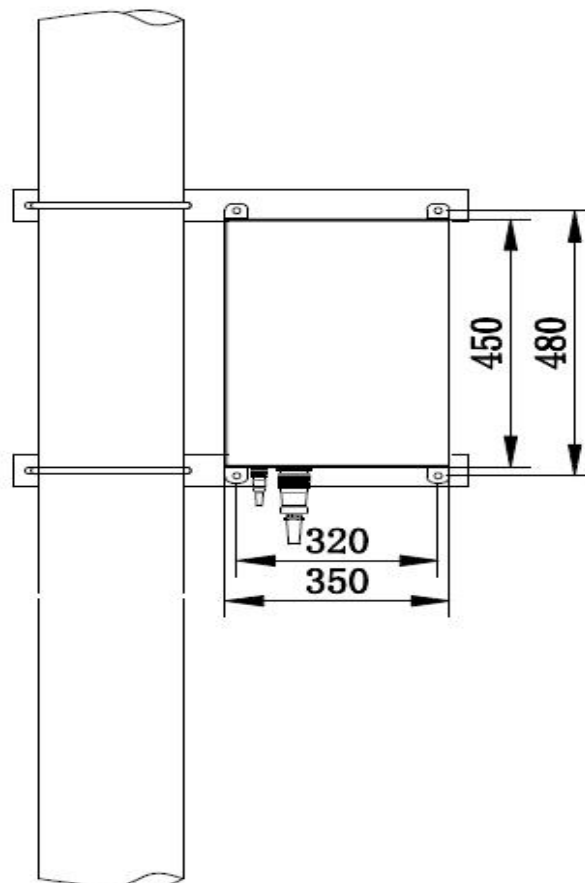

RWK-2RC installation schematic and dimensions

Cabinet installation

Installation of Box Body

- Please fasten it upon support shelf with matched M10 × 20 stainless bolts during installing the product. (Support shelf is provided by user, please point it out if needed to be provided by manufacturer)
- As shown above, place it up side. Don't place it up side down or in slope.

6.2 Maintenance

- If the device is not used, it should be kept in dry and ventilated places indoors, and charged once every three months, the charging time should be more than 24 hours. Before the device is used, the charging time should not be less than 24 hours. Replace the storage battery each three years.
- This device has storage battery management module, which will automatically cut off the storage battery output circuit when the storage battery voltage is on the low side. You should check the storage battery each year, please replace the storage battery immediately when single storage battery voltage id lower than DC12V.
- Please firstly make sure the first system is power off before the device is maintained, forbid inserting or pulling out aeronautical connector under power, thus avoid CT short circuit happening.

6.3 Parts Attached with the Device

Name	Quantity	Collocation	Usage or Description
Box door key	2	Standard	Open the box
User Manual	1	Standard	Please read it carefully before use the device, RWK-2RC wiring diagram is attached.
Inspection report	1	Standard	Factory inspection report
Hand-held telecontroller	1	Selectable	Telecontrol the close and trip of switch within 30 meters
Communication Interface	1	Selectable	RS485/USB converter or RS485/RS232 converter
Control Cable	1	Standard	20 cords (6 meters)
Control Cable	1	Standard	2 cords (6 meters)

Chapter 7: Decommission and Disposal

7.1 Decommission

Shut-down Power Supply

Shut-down Device Power Supply: Turn off external power supply switch of the device.

Disconnect All Power Cables

Disconnect all power cables connected to the device.

Danger: Before disconnecting all power cables connected to the device power module, it must confirm that the external power switch is turned off to avoid danger.

Danger: Disconnecting all power cables connected to the device alternating current module, it must confirm that the equipment corresponding to input alternating component has stopped operation to avoid danger.

Dismantle from Display Cabinet

When the above steps are completed, loosen the fix screws and dismantle the device from the display cabinet.

Danger: When neighboring equipment is in operation, it must strictly confirm the safety distance between the dismantled device and other device in operation and unskilled professional shall take particular caution.

7.2 Disposal

When dispose decommissioned device, please follow relevant regulations of the country where the product is used for the disposal of scrapped electronic products.

Caution: It must strictly adhere to relevant regulations of the country where the product is used for the disposal of scrapped electronic products.