

UFCL-SERIES Limiter

Cost-effective
reliable
proven

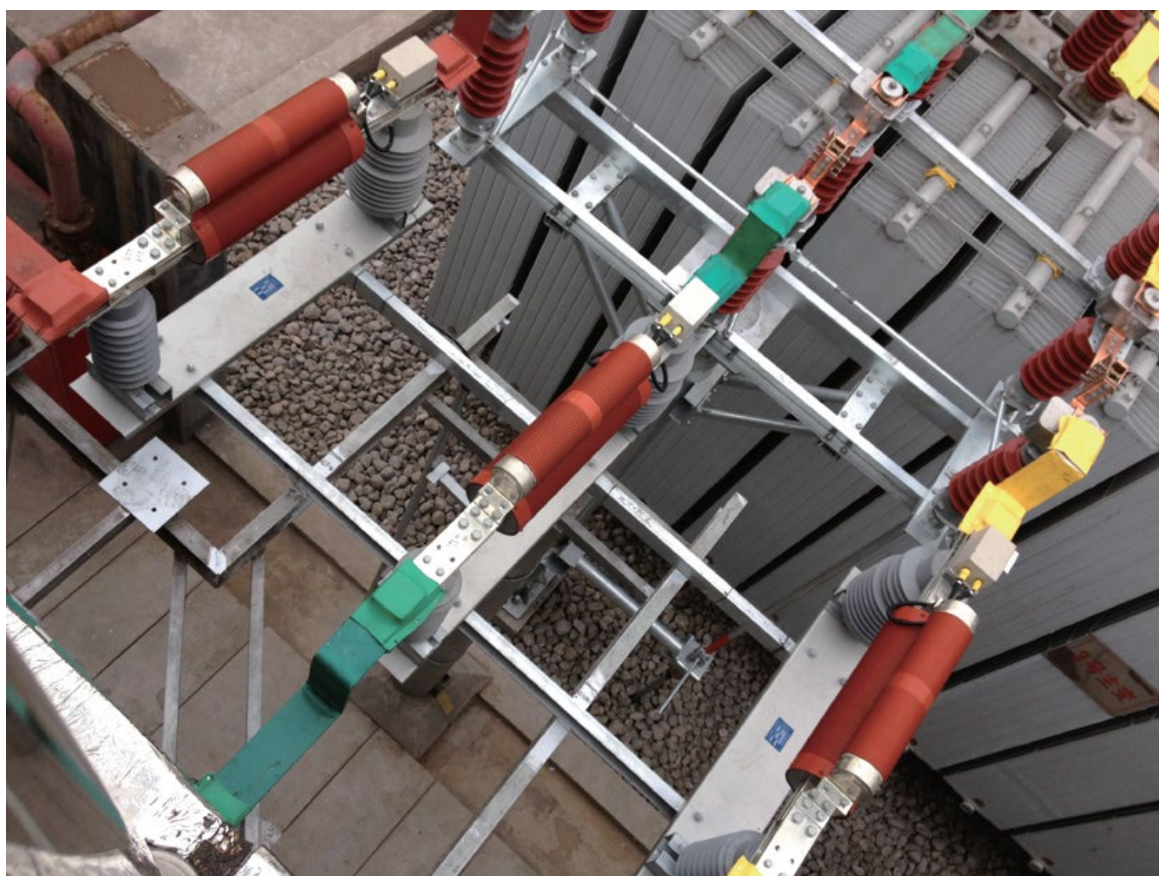

Comply with KEMA Lab. tested
Third-party inspection at FAT is available for further quality reassurance
Whole solutions for design, assembly, test...
Accountable solution for safety and reliability
easy business and ready to use out of the box



Table of contents

<http://www.rw-relay.com>

About us / contact us	1
Summary	2
Main characteristics	3
Working principle	4
System components	5
technical parameters	6
Applications	8
After-sales service	12



Zhejiang Rockwill Energy Technology Co., Ltd. is a technology enterprise specializing in providing complete solutions for power automation system and related automation system supporting equipment.

The company has a long-term strategic cooperation with internationally renowned middle and high voltage electrical equipment R & D and manufacturing companies and research institutes, and has jointly developed a series of high-quality automation products,. The company has also married with the provincial intelligent high-voltage switch laboratory to jointly develop a new generation of intelligent synchronous switch measurement and control devices, electronic transformers, voltage sensor processing units, etc., and has achieved some fruitful technical achievements and accumulated a large number of industry professional and technical elites with excellent experience. Solid talent base, advanced production equipment, perfect quality system, strict testing means, is a strong guarantee for the company's product quality alone.

In addition to providing a rich choice of products, we can provide you with technical solution support services, you only need to tell us your needs, our technical staff will be tailored for you to design a complete set of product solutions

The company is renowned at home and abroad for providing high-quality products and services. In addition to the domestic market, the products are currently exported to South America, Central Asia, the Middle East, Central Europe, Southeast Asia, Africa and other places. We always adhere to the belief of growing together with customers, and strive to provide safer, more reliable, more advanced and more humane automation system solutions and equipment.

ROCKWILL[®], China. Provide with best support.

If you have any question please consult below:

Email: support@rw-relay.com

Tel: [+86 \(577\) 27819965](tel:+86(577)27819965)

WEB station: <http://www.rw-relay.com/>

mobile: [+86 13867748881](tel:+8613867748881)

ROCKWILL® Energy strives to bring our customers the latest technology and competitive pricing and best service for distribution automatic.

The UFCL-limiter, a fault current limiter based on pyrotechnic technology, is a technological answer to the problem of higher levels of short circuit current where system augmentation takes place but replacing of whole protection switchgear is not feasible.

Faults in electrical power systems are inevitable. Apart from the damages in the vicinity of the fault - e.g. due to the effects of an electric arc - the fault currents flowing from the sources to the location of the fault impose high dynamical and thermal stresses on equipment like bus-bars, transformers, and switchgears. The circuit-breakers further have to be capable of (selectively) interrupting the currents associated.

But, a growth in the generation of electrical energy and an increased interconnection of the networks lead to higher fault currents. Especially, the continuous growth in the generation of electrical energy has the consequence that networks approach or even exceed their limits with respect to the short-circuit current withstand capability. Therefore, there is a considerable interest in devices which are capable of limiting fault currents. A fault current limiter can trip at the very early stage of first rise and limit the first peak of the fault current passing through it.

The use of UFCL-limiters allows equipment to remain in service even if the prospective fault current exceeds its rated peak and short-time withstand current and in case of circuit breakers also its rated short-circuit making and breaking current. Replacement of equipment can be avoided or at least shifted to a later date. In case of newly planned networks UFCL-limiters allow the use of equipment with lower ratings which renders possible considerable cost savings. In case of newly planned networks UFCL-limiters allow the use of equipment with lower ratings which renders possible considerable cost savings.

Sometimes, UFCL-limiter is the only solution

As shown in Figure 1 below, the UFCL-limiter is installed in the bus-tie section and is series-connected to the bus coupling circuit-breaker (CB). In the event of a short-circuit in the outgoing feeder, the prospective short-circuit current flowing through the outgoing feeder CB (I_k'') may reach 80kArms, which is equivalent to a peak current of 200kAp. This exceeds the ratings of the CB (40kArms and 100kAp). In other words, the CB is unable to provide protection against this high peak short-circuit current and the operation speed of the CB is too slow. This will lead to serious mechanical and thermal stress and eventually equipment failure.

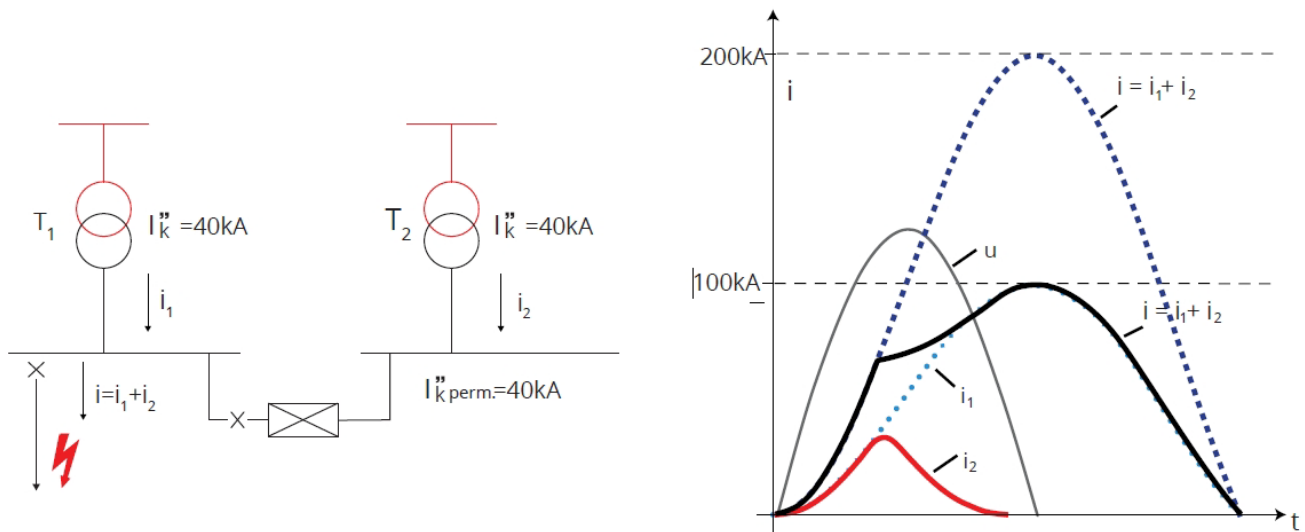

Figure-1

However, thanks to the high operation speed and current limiting capabilities of the UFCL-limiter, it is possible to resolve this issue without upgrading all the equipment in the system. By installing the UFCL-limiter on the strategic position of the bus-tie, the short-circuit current i_2 contributed by T2 is limited at the rise of the first cycle and interrupted before the prospective current i_2 reaches its peak. The total (peak) short-circuit current flowing through the CB of the fault circuit is then kept below 100kAp ($i_1 + i_2 < 100$ kAp), which is the rated peak withstand current of the CB. Therefore, the CB can withstand the fault current and trip to clear the fault safely.

In comparison with complex conventional solutions, the UFCL-limiter has both technical and economic advantages when used in transformer or generator feeders, in switchgear sectionalizing and connected in parallel with reactors. There is no need for customers to upgrade all the switchgear, bus-bars cables, etc.

The advantages of the use of a UFCL-limiter in a network are:

- Reduction of the short-circuit current of the system (compared to the short-circuit current with closed tie circuit breaker)
- Reduction of voltage sags and flicker due to the lower total source impedance
- Reduction of harmonics due to the lower total source impedance
- Higher system availability due to the parallel connection of the feeding generators and transformers
- Higher loads possible in a sub-system (higher than the ratings of the feeding generators and transformers in that sub-system)

How does UFCL-limiter work?

Principle

The interrupting device of UFCL-limiter, also known as current limiter inserts, consists of two parallel components:

- An ultra-fast interrupter - main conductor
- A special current limiting fuse - parallel fuse

Under normal operation, the load current flows through the main conductor. When the tripping signal is triggered, the main conductor will be opened in a very short time, then the fault current is commutated to the parallel fuse. The fuse then limits and breaks the instantaneous current within the first half cycle.

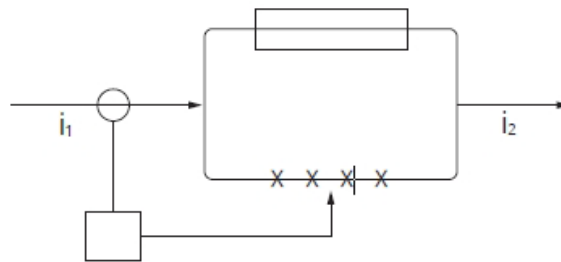

Figure-2

Current transformer

A current transformer is installed in the insulating tube with an ultra-fast interrupter, which measures the current flowing through UFCL-limiter continuously and transmit the real-time values to the tripping unit. Rogowski type current transformer has remarkable features of extremely high over-current factor and high precision.

Pyrotechnic switch

The pyrotechnic switch or an ultra-fast interrupter is designed as a bursting bridge, that contains multiple charges. These charges are triggered by a tripping signal and the ultra-fast interrupter opens at the rupture points rapidly.

Special current limiting fuse

Current limiting fuse is used to limit and break the short-circuit current. The over-voltage level will not exceed the standard IEC 60282-1.



Figure-3

Tripping unit

A tripping unit monitors and evaluates the current supplied by the tripping current transformer continuously. It determines whether tripping is necessary or not. The three tripping units (one per phase) work independently of each other.

Tripping criteria are as follows:

- The instantaneous current value and
- The rate of current rise

We put safety first

Bursting bridges along rectangular main conductors, multi-charge structure make redundancy.

Tripping units are located on the high-voltage side and built-in anti-interference units to reduce electromagnetic interference and enhance reliability.

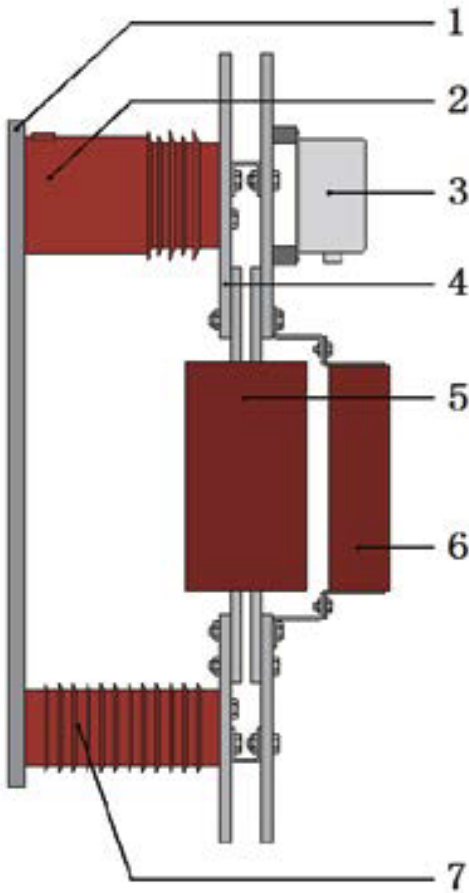

Figure-4: UFCL-limiter 12kV, 4000A (1 phase)

1. Base plate
2. Isolation transformer
3. Tripping unit
4. Bus-bar
5. Ultra-fast Interrupter
6. Special current limiting fuse
7. Insulator

Monitoring and indication unit

The monitoring and indication unit continuously monitors the basic function of the UFCL-limiter and provide local and remote indication for:

- Trip signal for each phase (three in total);
- Monitoring of readiness for operation;
- Monitoring of the supply voltages.

Isolation transformer

An Isolation transformer provides auxiliary voltage for the tripping unit, the auxiliary voltage is taken from power unit installed in the monitoring and indication unit. Besides it is also the channel for the tripping unit to output the tripping signal to indication unit.



Figure-5 Monitoring and indication unit

UFCL-limiter switchgear

Rated voltage	kV	7.2	12	17.5	24	36	40.5
Rated current	A	1250-6300		1250-4000		1250-3150	
Rated frequency	Hz	50/60					
Rated power-frequency withstand voltage	kV	20	28	38	50	70	95
Rated lightning impulse withstand voltage	kV	60	75	95	125	170	185
Rated auxiliary voltage	V	AC220/230					
Installation type		Cabinet					



UFCL-limiter in loose equipment supply

Rated voltage	kV	7.2	12	17.5	24	36	40.5
Rated current	A	1250-6300		1250-4000		1250-3150	
Rated frequency	Hz	50/60					
Rated short-circuit breaking current	kA _{rms}	Up to 200					
Rated power-frequency withstand voltage	kV	20	28	38	50	70	95
Rated lightning impulse withstand voltage	kV	60	75	95	125	170	185
Tripping time	ms	< 1					
Total operating time	ms	< 10					
Peak current limiting ratio	%	15-50					
Rated auxiliary voltage	V	DC 110/220; AC 110/220/230					
Installation type		Install in the form of loose parts					



Flexible solutions ensure an interruption-free power supply

UFCL-limiters in system interconnections

UFCL-limiters are frequently used in interconnections between systems or in bus sections which would not be adequately short-circuit proof when connected by a circuit-breaker. Each sub-system should have at least one incoming feeder, so that the power supply to each sub-system can be maintained on tripping of the UFCL-limiter. There numerous advantages for the operation under normal conditions of bus sections.

Connected by UFCL-limiters:

- Reduction of the series network impedance. The voltage drops caused by load
- Improvement of the current distribution at the feeder transformers
- The load dependent losses of the feeder transformers are reduced
- Increased reliability of the power supply

On failure of one feeder transformer, the load is taken over by the other feeder transformers without current interruption. On the other hand, the cost of required new switchboard with higher short-circuit capacity will be saved.

If a short-circuit occurs within a system or in an outgoing feeder, the UFCL-limiter trips at the first rise of the short-circuit current and splits the bus-bar into two sections before the instantaneous current reaches an impermissible high level.

After tripping of the UFCL-limiter, the short-circuit is only fed by the transformer in the part of the system affected by the short-circuit. The short-circuit current is now selectively interrupted by the circuit-breaker. A remarkable advantage of the use of an UFCL-limiter is that the voltage in the part of the system not affected by the short-circuit only drops for a fraction of a millisecond so that even sensitive loads (e.g. data centers) remain protected from drops in the system voltage.

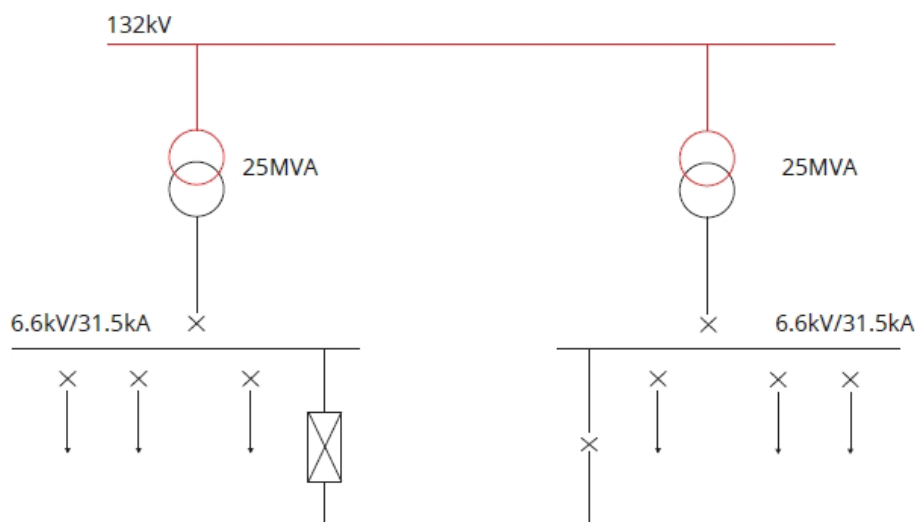

Figure-6

UFCL-limiter installed in generator feeders

When a new generator is connected to the grid, the additional short-circuit current from generator leads to the prospective short-circuit current in the utility network being exceeded. The best technical solution and mostly the only one is the installation of UFCL-limiter in the interconnection with the public utility network, this application's advantages are:

- Generator can be connected regardless of the short-circuit capability of the system
- Existing bus-bar and cable systems don't have to be changed
- No need of expensive generator breaker

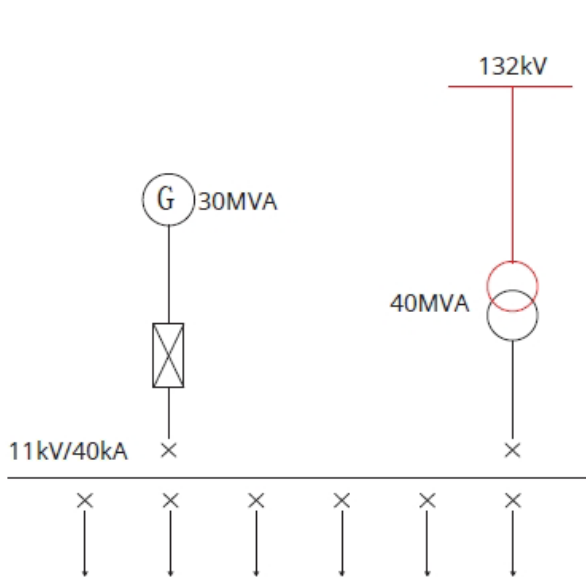

Figure-7

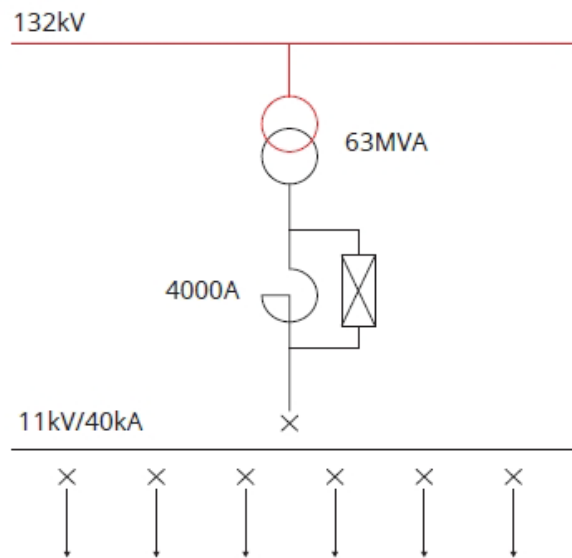

Figure-8

UFCL-limiter in parallel with reactors

UFCL-limiter is connected in parallel with a reactor (Figure 8). If a short-circuit occurs behind the reactor, the UFCL-limiter trips at the first rise of short-circuit current and the current commutates to the parallel reactor, which then limits the short-circuit current to the permissible level. For normal operation, the UFCL-limiter bypasses the reactor coil, this application's benefits are:

- Avoids current dependent copper losses and the associated operating costs of the reactor
- Avoids current dependent voltage drop at the reactor, which frequently causes major difficulties on start-up of big motors
- Control problems with the generator

Expansion of the existing system

As shown in Figure 9, When interconnecting the existing system with a new system or connecting a customer's power generation system with the public utility, the short-circuit current level may exceed the permissible ratings of the existing system, but not the new system. Our fault current limiter, the UFCL, not only can solve the short-circuit current problem, but it can also realize directional tripping and avoid unnecessary tripping, that's is, a selective tripping. Function with the addition of a selective tripping unit (STU) based on the closely related node technology (CRNT):

- When a short-circuit fault occurs on bus A, and the prospective short-circuit current exceeds its permissible rating, i.e. $I_k'' > I_{k,perm.1}$, the UFCL will trip to protect bus A and its subsystem
- When a short-circuit fault occurs on bus B, and the prospective short-circuit current remains below its permissible rating, i.e. $I_k'' < I_{k,perm.2}$, the UFCL will not trip.

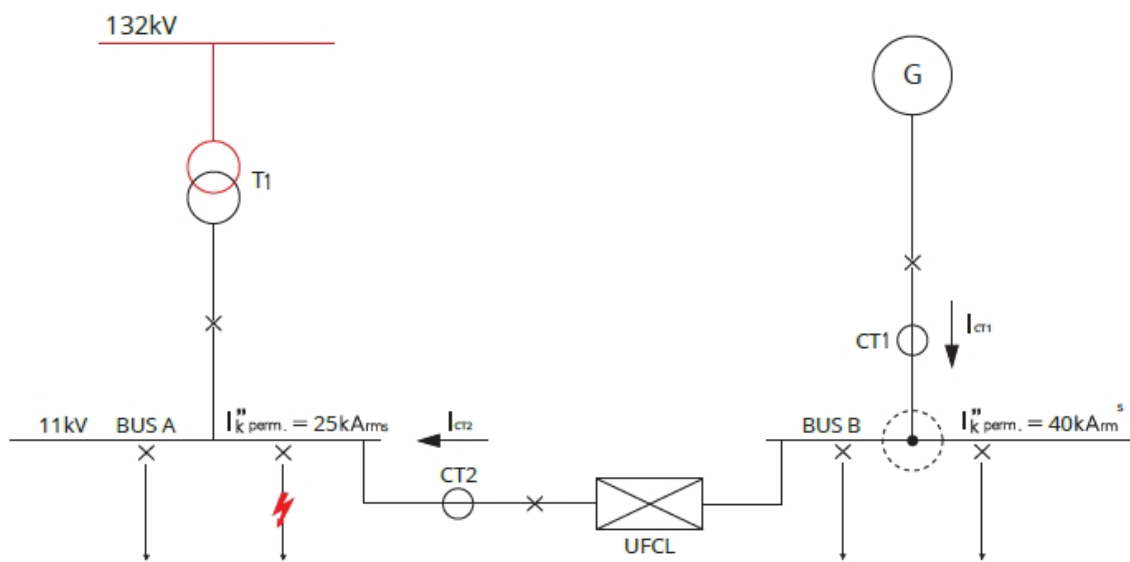

Note:  Closely related nodes

Figure-9

Parallel operation of multiple sources

As shown in Figure 10, Industries often use parallel operation of multiple power sources to improve power supply reliability, load balance, and stability.

However, this can lead to short-circuit current levels exceeding the permissible ratings. Such an operation requires multiple FCLs to limit the short-circuit current and must trip selectively based on fault location. This can be achieved with STU based on CRNT, that is:

- When a short-circuit fault occurs on bus A and the prospective short-circuit current level exceeds its permissible rating, only UFCL1 will trip to protect bus and its subsystem
- When a short-circuit fault occurs on bus B and the prospective short-circuit current level exceeds its permissible rating, UFCL1 and UFCL2 both will trip bus and its subsystem
- When a short-circuit fault occurs on bus C and the prospective short-circuit current level exceeds its permissible rating, only UFCL2 will trip to protect bus C and its subsystem.

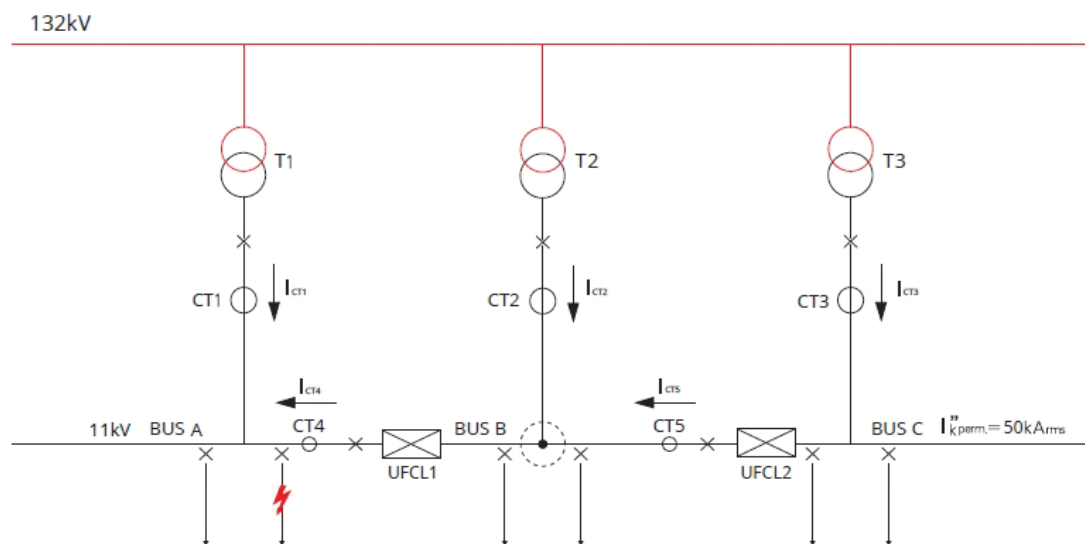

Note:  Closely related nodes

Figure-10

The coordination between selective tripping unit (STU) and tripping unit (ITU3)

The STU is a controller used when selective tripping is required for a system. The STU uses the current data from the nearby current transformers to realize the quick identification of the faulty section based on current direction and magnitude.

This unit needs to work in conjunction with the tripping unit ITU3, its criteria form an "AND" logic with the criteria of the ITU3 (the instantaneous current and the rate of current rise). Once the criteria of the STU are met, the STU will send an enabling signal to the corresponding FCL's ITU3. The corresponding FCL(s) will trip. Other FCLs that didn't receive the enabling signal from the corresponding STU will not trip even the setting value of their ITU3 has been met.

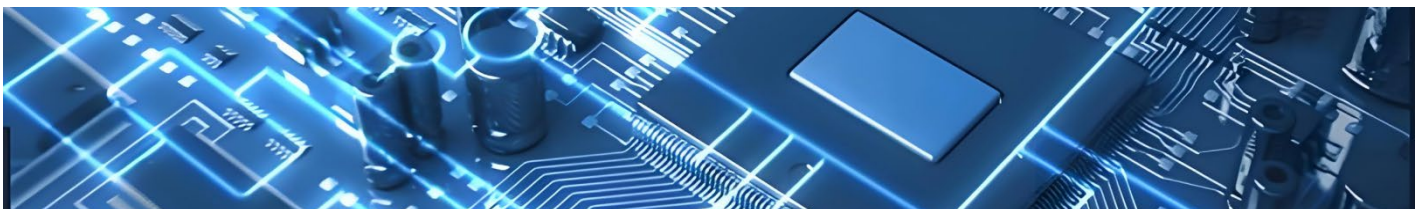

Field service operation and warranty issues:

ROCKWILL® can provide competent, well trained field service representatives to provide technical guidance and advisory assistance for the installation, overhaul, repair and maintenance of ROCKWILL® equipment, processes and systems.

ROCKWILL® service Tel: [+86 \(577\) 27819965](tel:+8657727819965)/[+86 13867748881](tel:+8613867748881)

Email: support@rw-relay.com

Or check the website information: <http://www.rw-relay.com>